

# DESIGN A CARPET



Faig Ahmed, *Gautama*, 2017, Handmade wool carpet, 284 x 378 cm,  
on loan from Collection Majudia, Montreal.

Azerbaijani artist Faig Ahmed plays with the designs of traditional carpets by disrupting their size, colour, pattern, and direction, making new works in the process.

You can sample his way of working by creating your own carpet design on the gridded floorcloth on page 4, or by drawing a rectangle on a large sheet of paper and using that as your base. Print and cut out the motifs on pages 2 and 3, or just use them as your guide, adding more design elements of your own. You can also draw a design completely freehand. Experiment with stripes, pixels, or freeform shapes as Ahmed does.

The motifs for your “carpet play” are taken from a very special carpet from Azerbaijan in the collection of the Textile Museum of Canada (TMC), which you can see by following this link:

<https://collections.textilemuseum.ca/collection/6842/>

Carpet making is an ancient art form, and carpets from the Caucasus region of the world are particularly bold and colourful. They almost always have a border and central motifs that anchor the design. Some carpets, like this one, feature stylized dragons and birds. Try creating a design on your own and then compare it to the Textile Museum of Canada’s carpet. Yours is bound to be unique, for there are a million ways to design a carpet!

## MOTIFS FOR YOUR CARPET

Print and cut out the black outlines of the carpet motifs or use them as inspiration for your own creations. Make multiples of any of them as your design suggests.

Colour them and put them on the floorcloth, moving them around, nesting small ones inside of big ones if you like, until you are happy with your design.

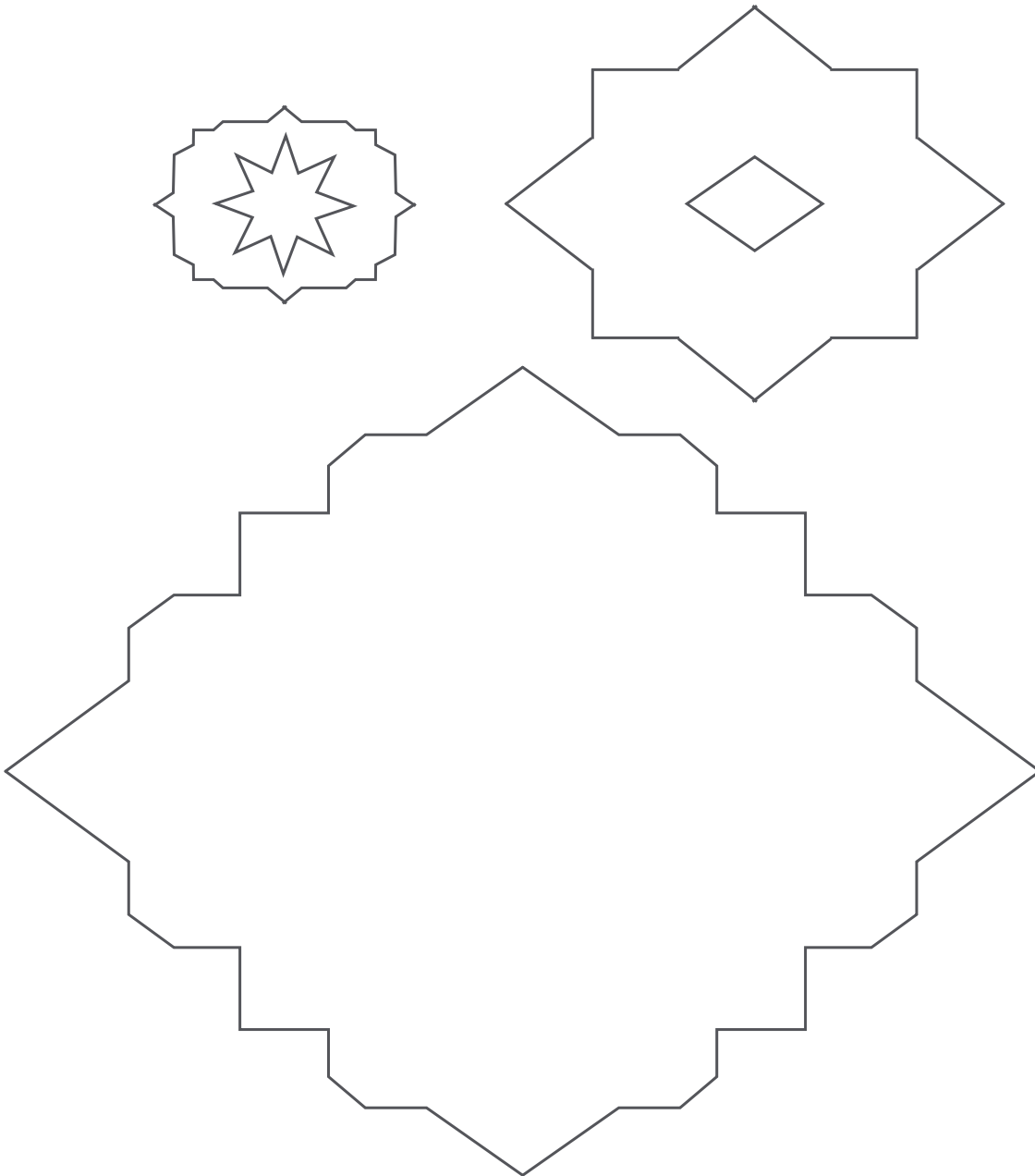

### FROM THE TMC CARPET



three medallions

When your carpet design is complete, take a photo and share it with us to this address: [learn@agakhanmuseum.org](mailto:learn@agakhanmuseum.org)

Make sure your photo is 10 mg or smaller. Selected photos may be posted to the “Faig Ahmed: Dissolving Order” web page.

## MORE MOTIFS FOR YOUR CARPET

Print and cut out the black outlines of the carpet motifs or use them as inspiration for your own creations. Make multiples of them as your design suggests.

Colour them and put them on the floorcloth, moving them around, nesting small ones inside of big ones if you like, until you are happy with your design.

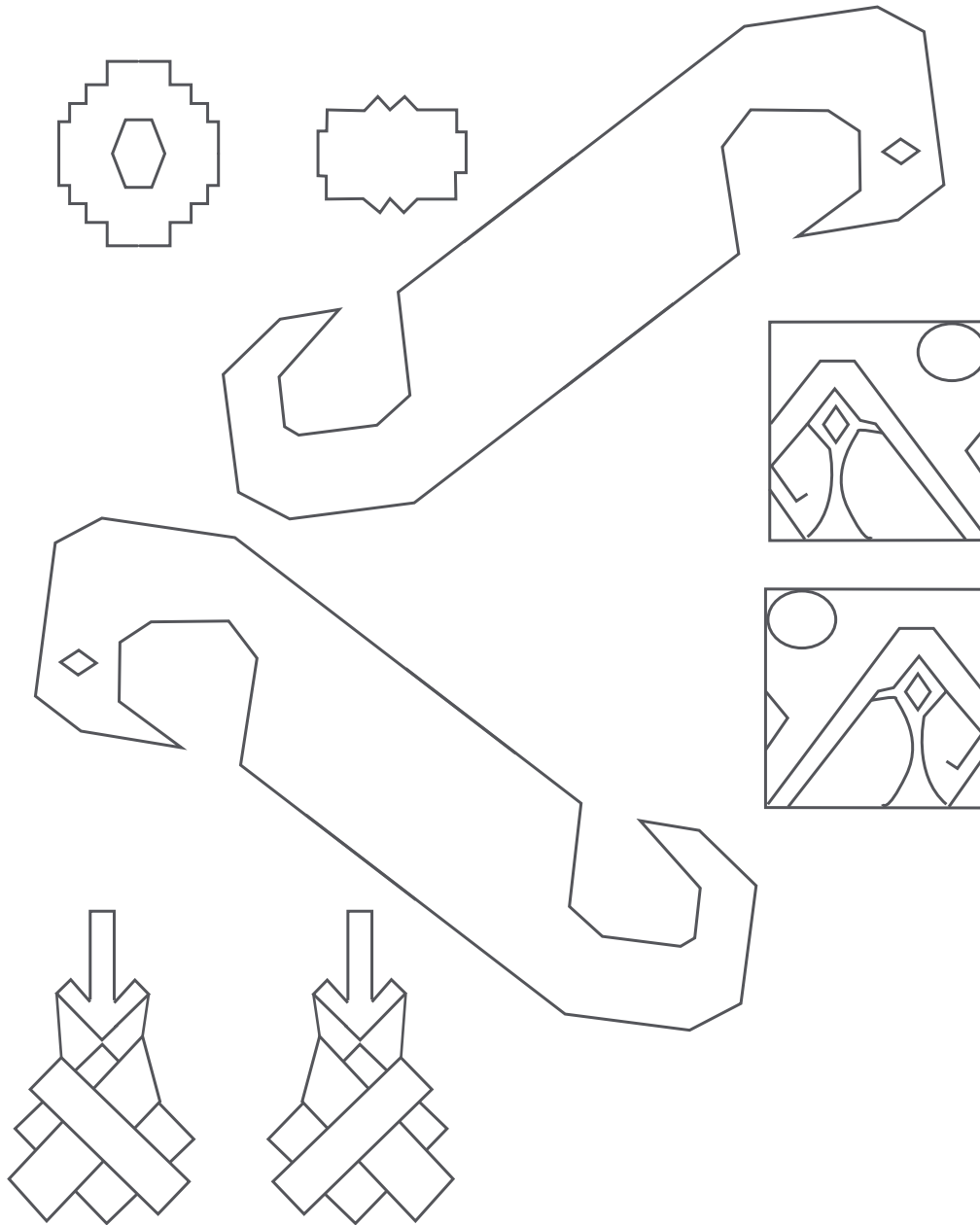

The knot, bird, and dragon motifs on this page have “flipped” versions, but the medallion and flower motifs do not. Why do you think that is?

### FROM THE TMC CARPET



medallion



flower



stylized knot



stylized bird



stylized dragon

## FLOORCLOTH FOR YOUR DESIGN

To make a large-sized (26 x 48.5 cm) floorcloth, print this pdf as a poster in Acrobat on US letter or A4 sized paper, tiling this page with a 1.5 centimetre overlap.  
Choose the poster option for all pages in the Acrobat “Print” dialogue box to preserve sizes; but select “Tile only large pages.”

